

F1 - FAÇANA PRINCIPAL

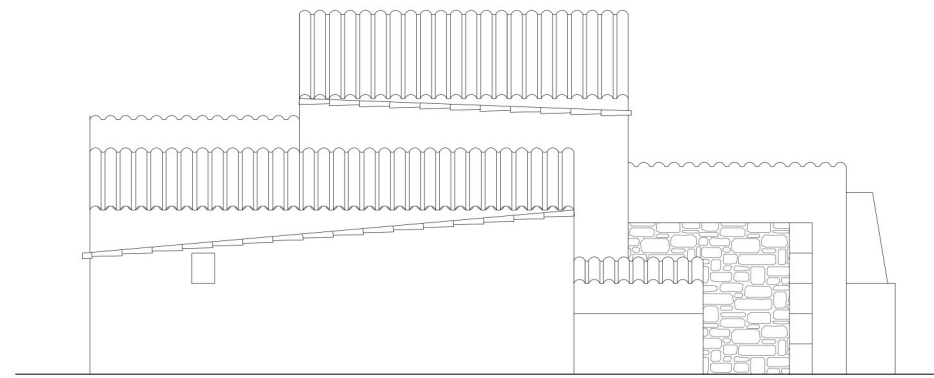

F2 - FAÇANA POSTERIOR

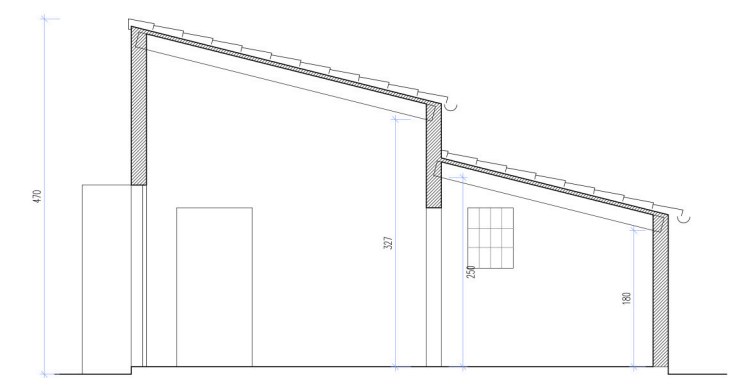

S1 - SECCIÓ PER SALA-MENJADOR-HABITACIÓ

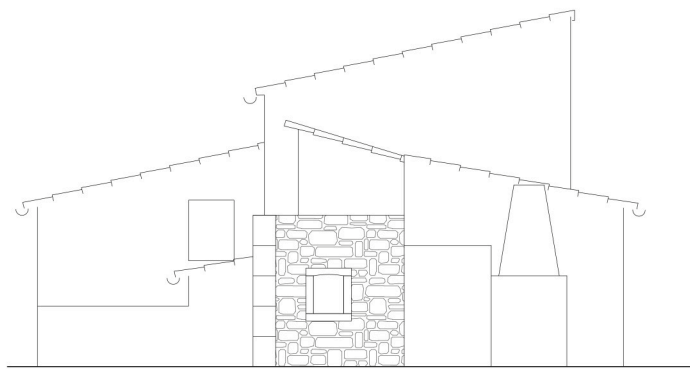

F4 - FAÇANA LATERAL ESQUERRA

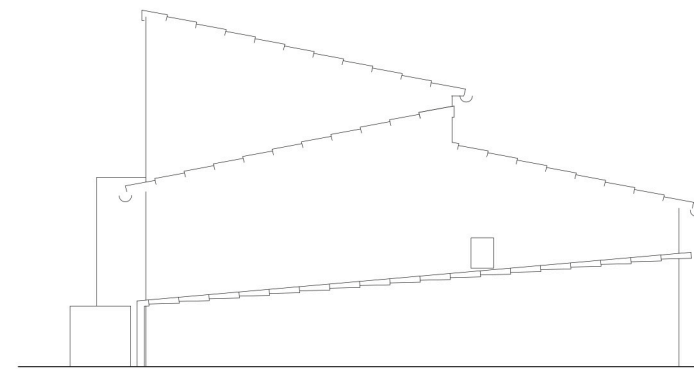

F3 - FAÇANA LATERAL DRETA

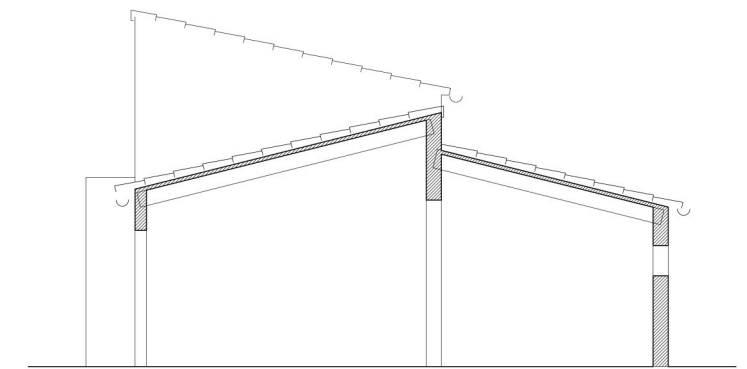

S2 - SECCIÓ PER MAGATZEM-TRASTER

IMATGES ESTAT ACTUAL

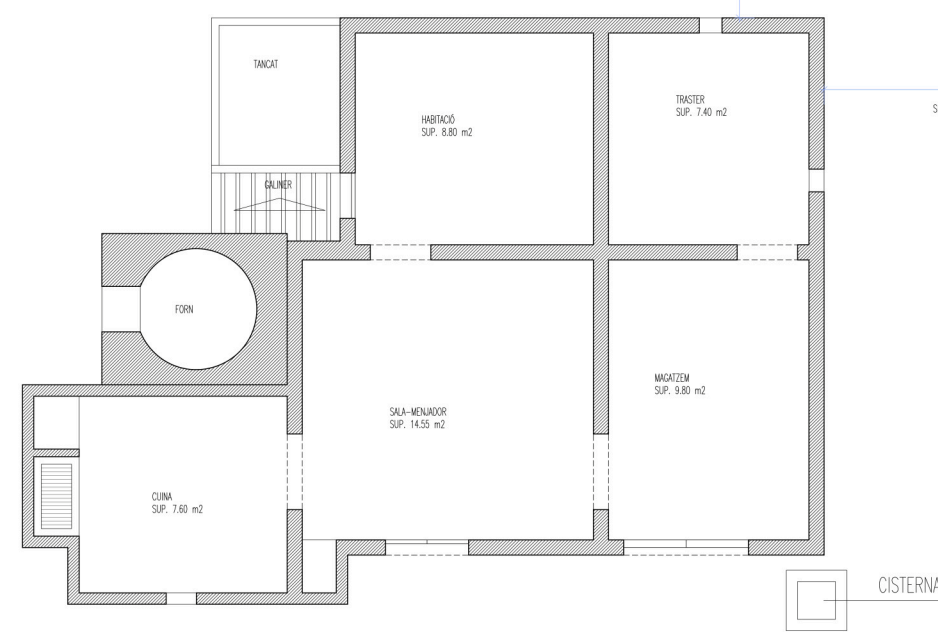

PLANTA BAIXA E:1/50

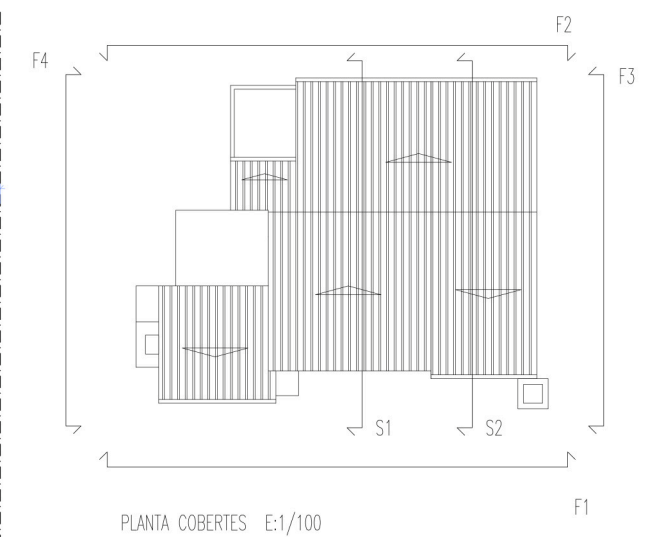

PLANTA COBERTES E:1/100

ESTAT ACTUAL

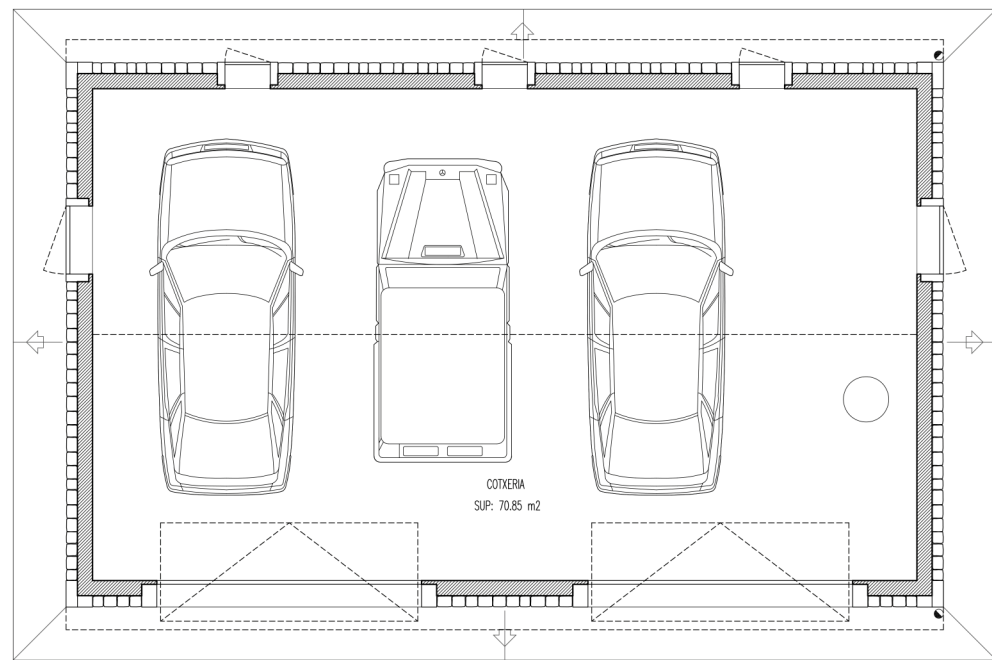

COTXERIA PLANTA BAIXA

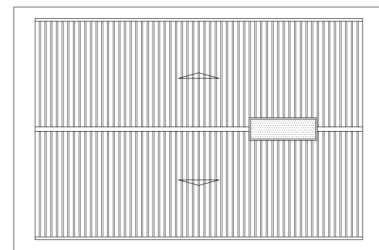

PLANTA COBERTES E.1/150

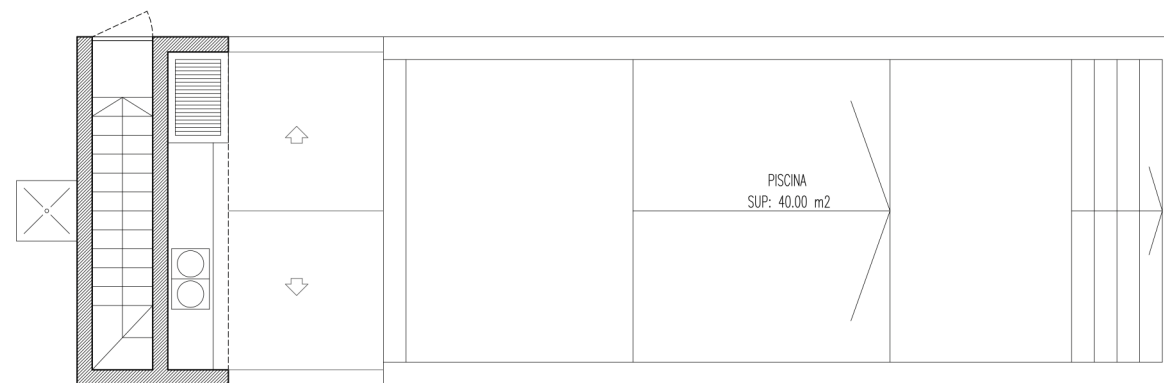
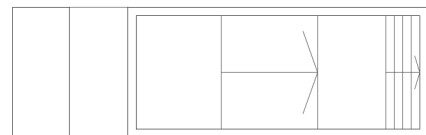
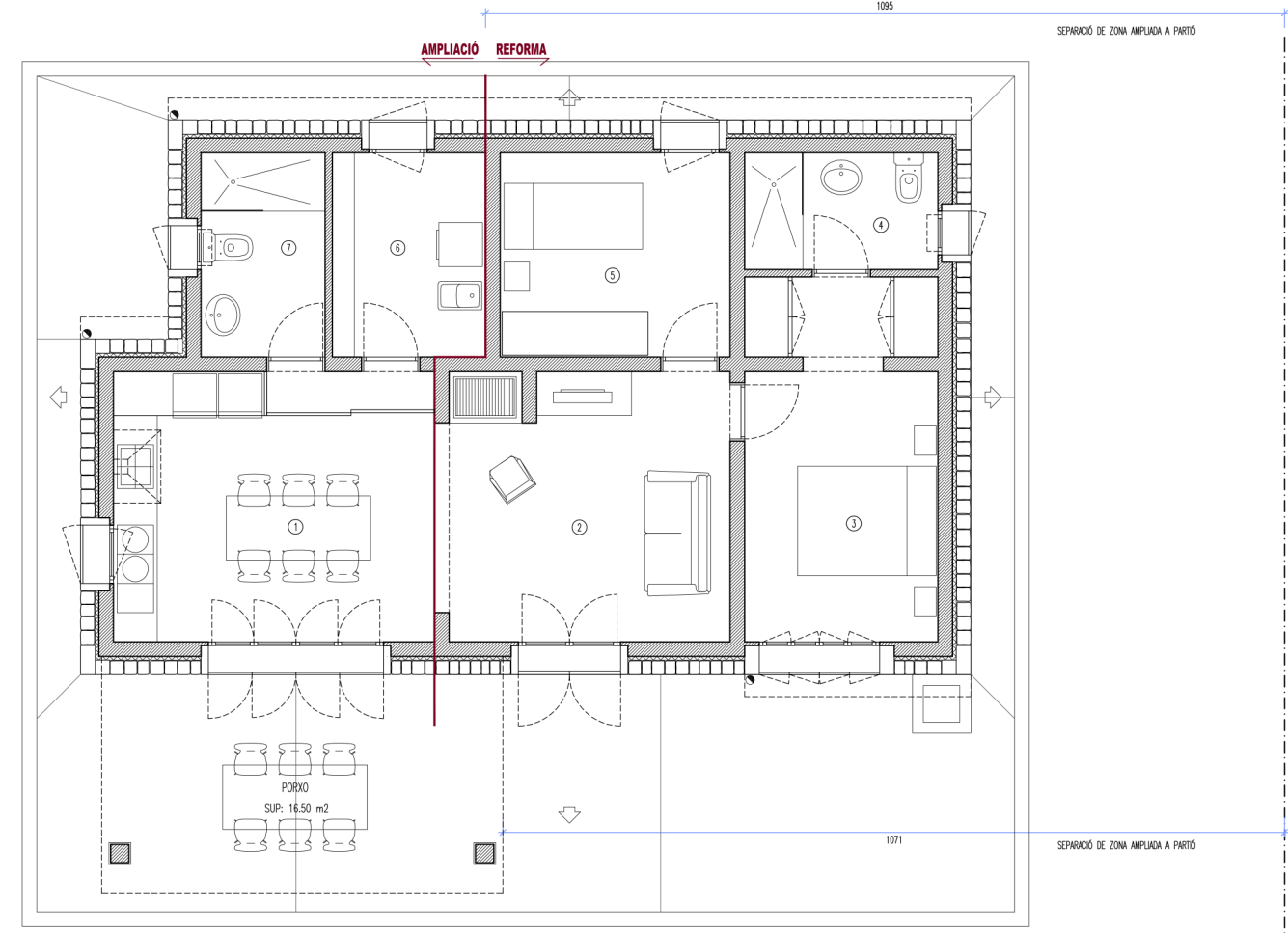
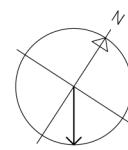
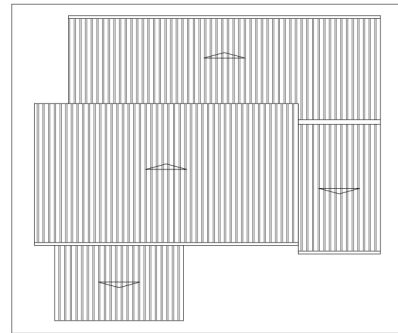

PISCINA-TORRADOR

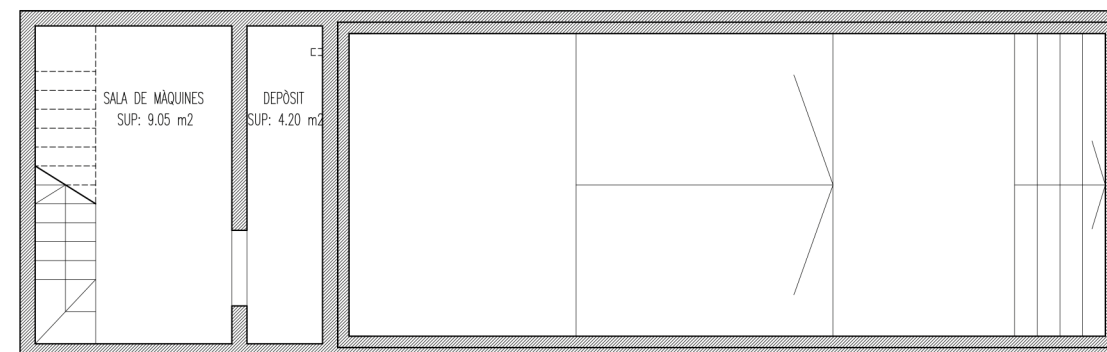

DETALL SALA DE MÀQUINES

PROPOSTA

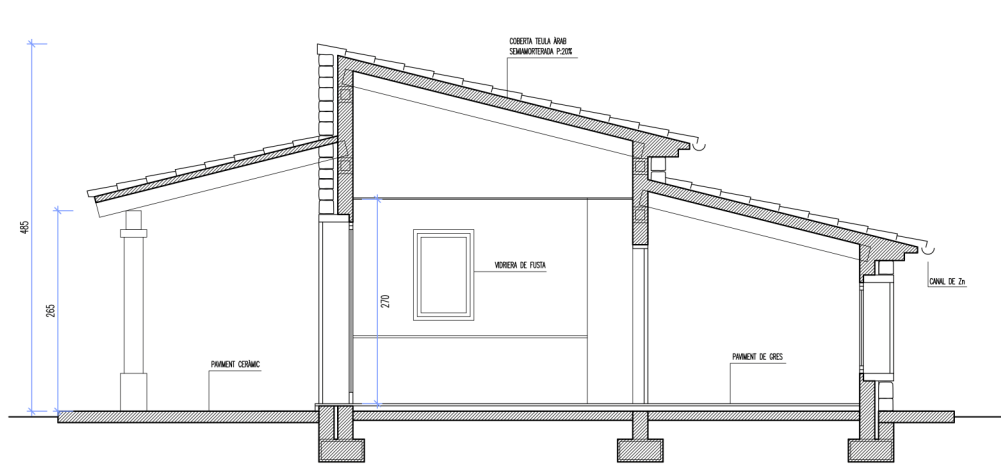

S1 - SECCIÓ PER PORXO-CUINA-BANY (ZONA AMPLIADA)

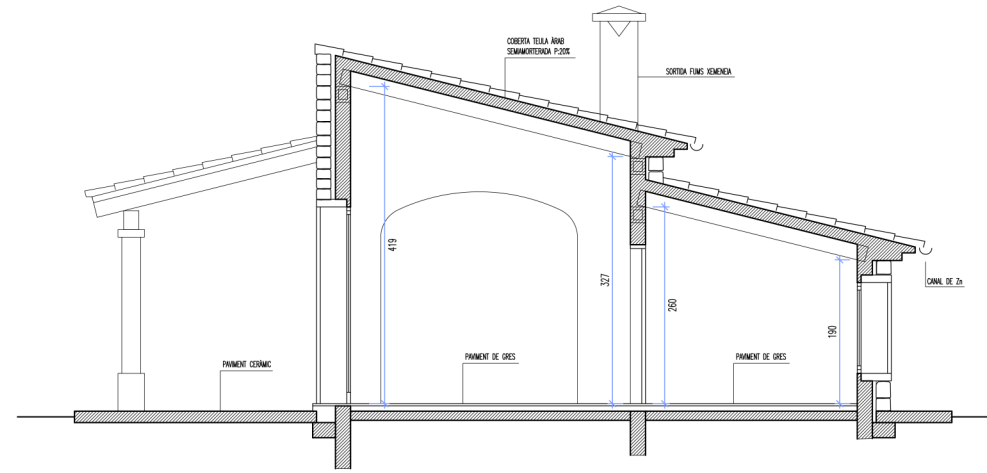

S2 - SECCIÓ PER SALA-HABITACIÓ (ZONA REFORMADA)

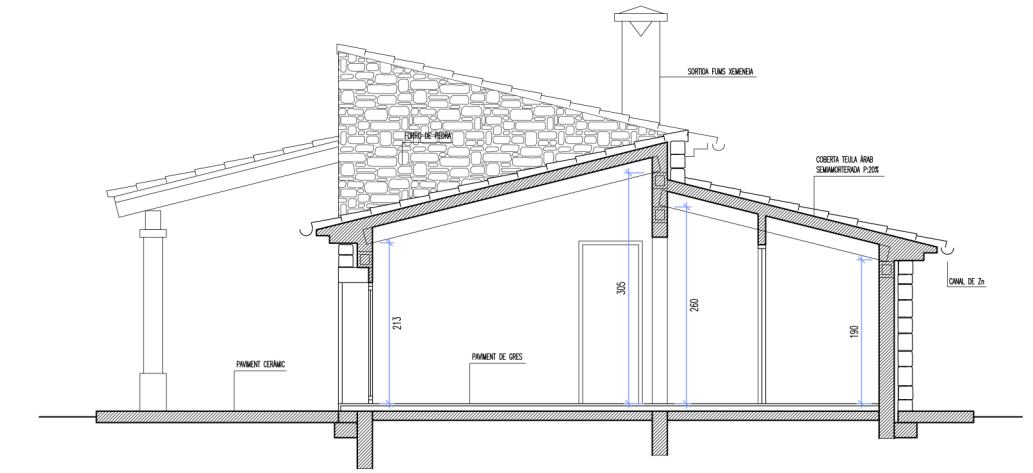

S3 - SECCIÓ PER HABITACIÓ-BANY (ZONA REFORMADA)

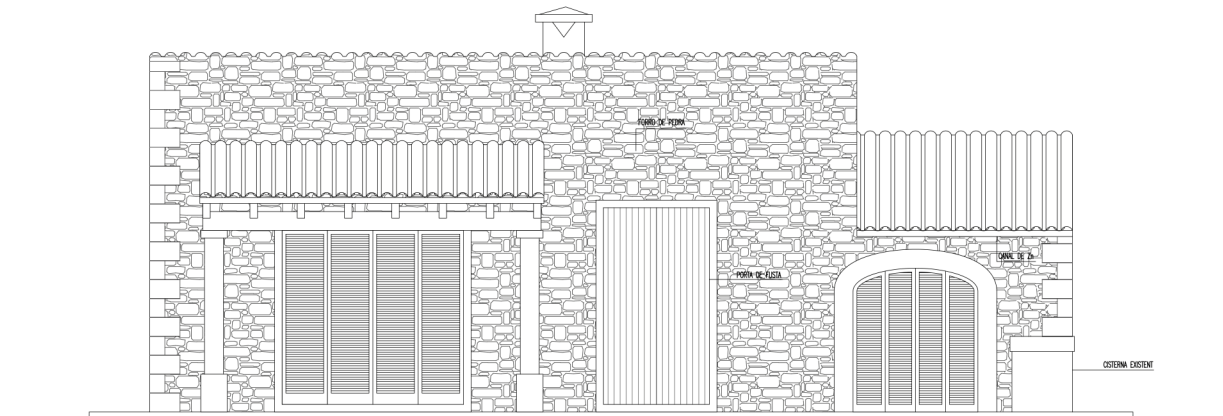

F1 - FAÇANA PRINCIPAL

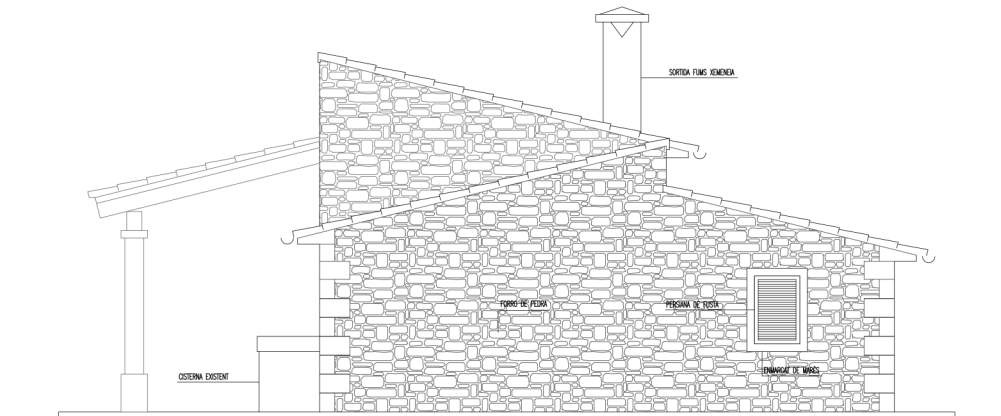

F2 - FAÇANA LATERAL DRETA

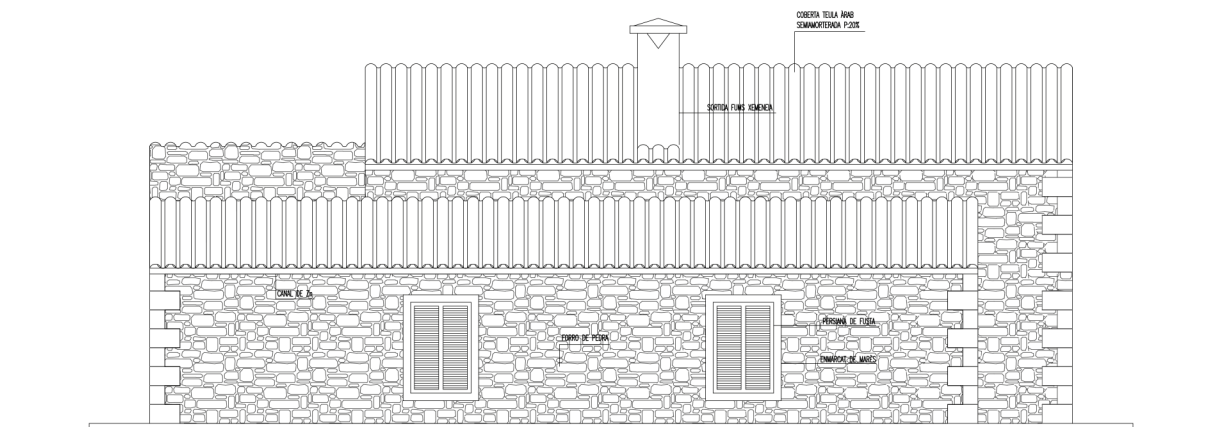

F3 - FAÇANA POSTERIOR

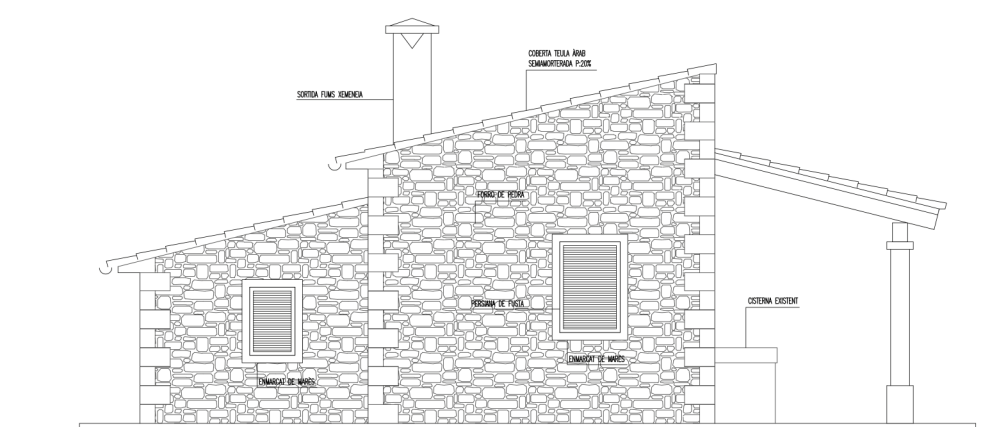

F4 - FAÇANA LATERAL ESQUERRA

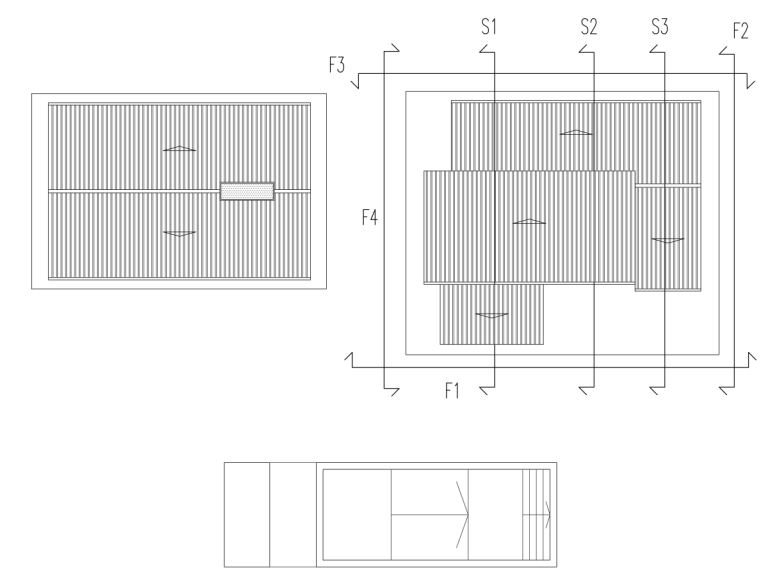

PROPOSTA

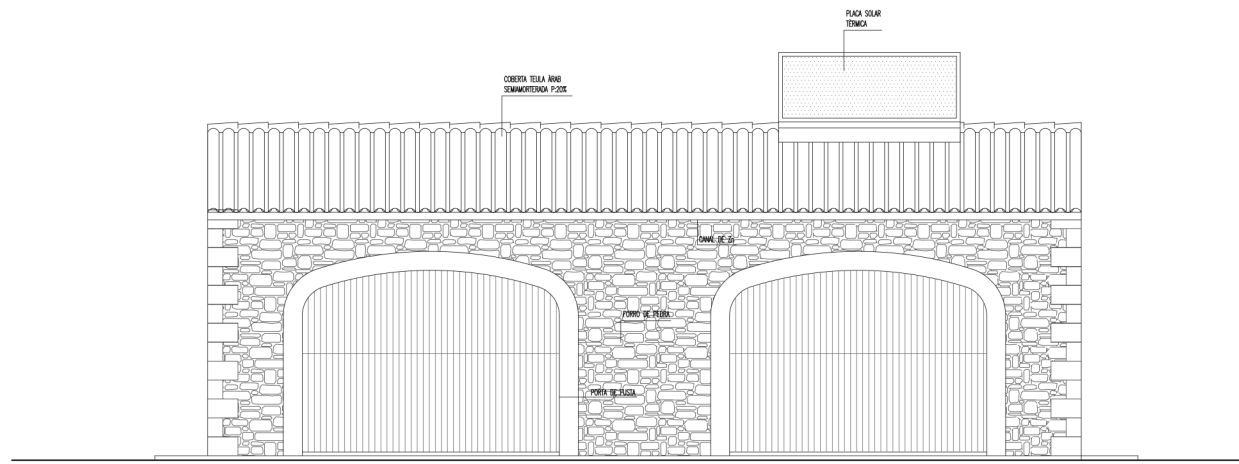

F1 - FAÇANA PRINCIPAL

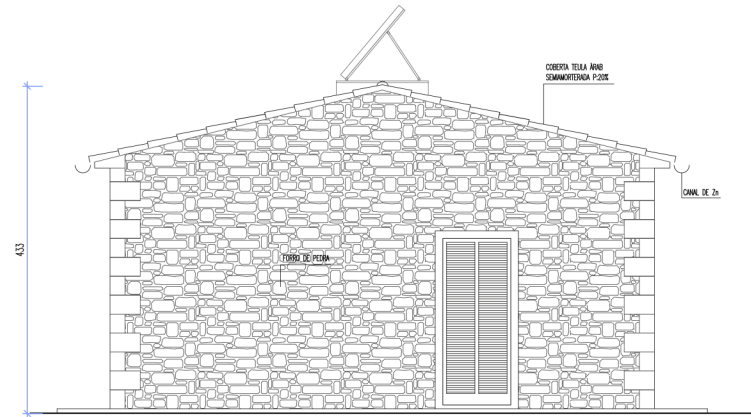

F2 - FAÇANA LATERAL DRETA

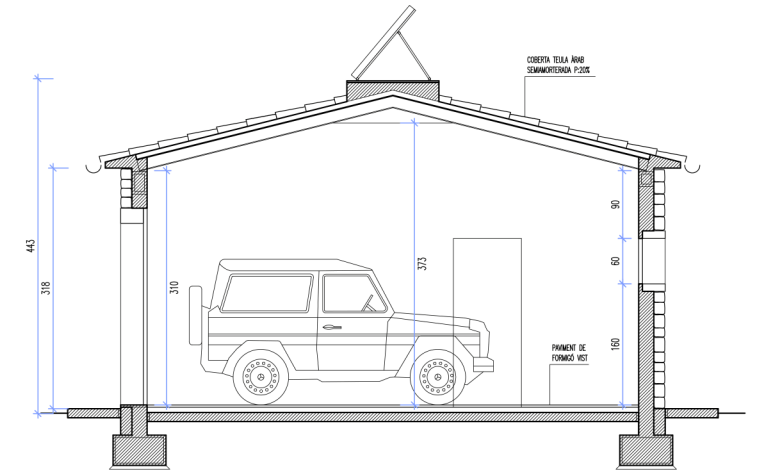

S1 - SECCIÓ TRANSVERSAL DE COTXERIA

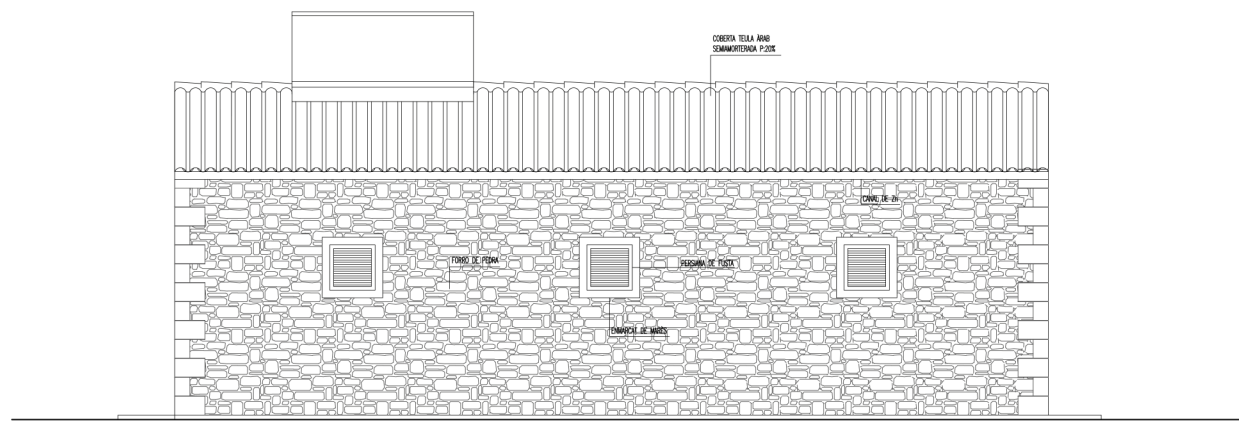

F3 - FAÇANA POSTERIOR

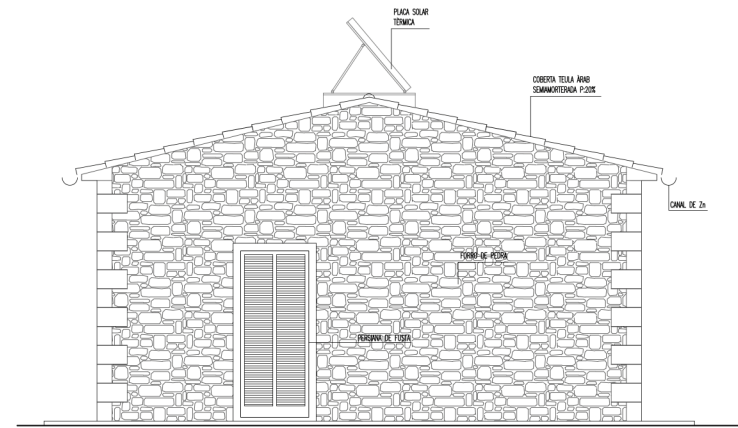

F4 - FAÇANA LATERAL ESQUERRA

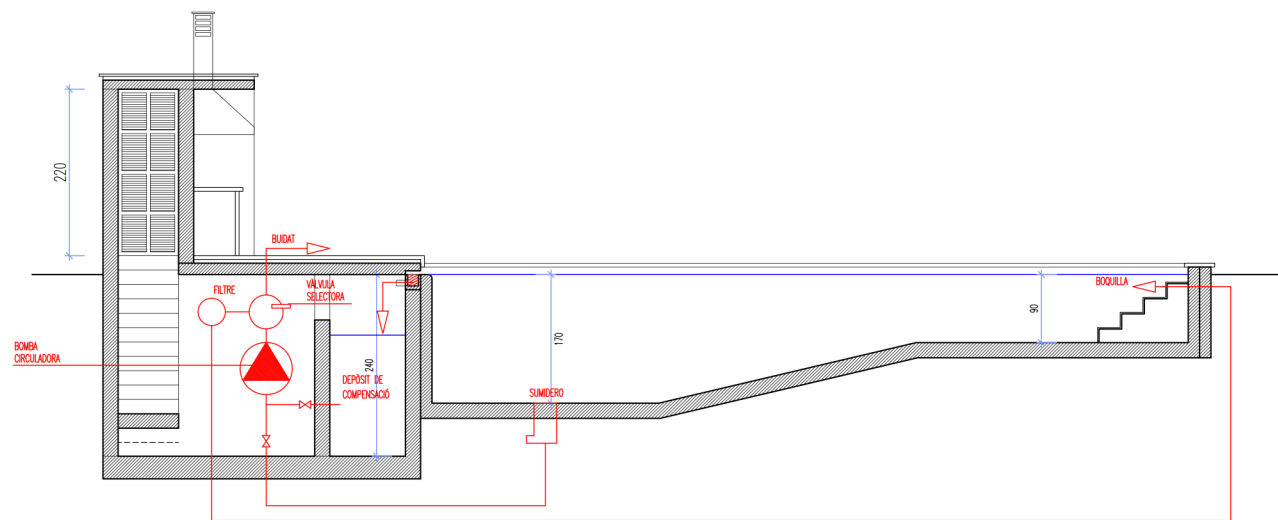
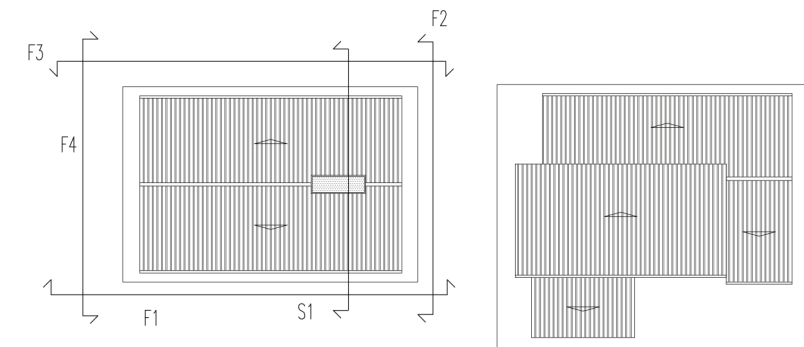

S2 - SECCIÓ PER PISCINA I SALA DE MÀQUINES

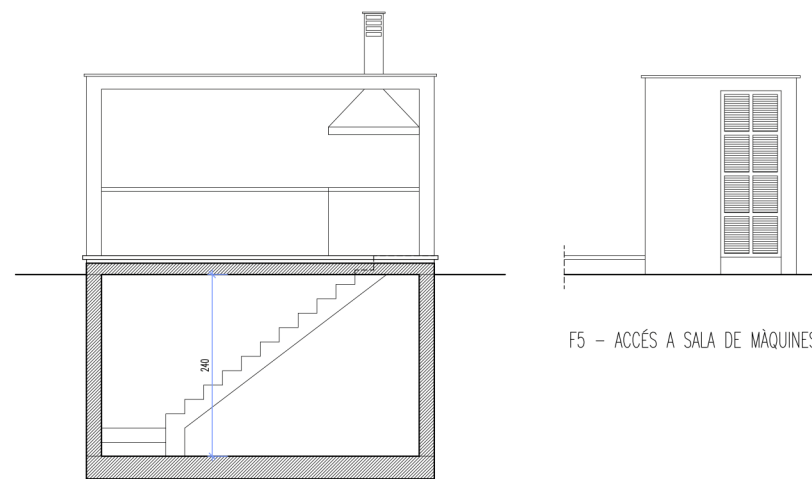

S3 - SECCIÓ TRANSVERSAL DE SALA DE MÀQUINES

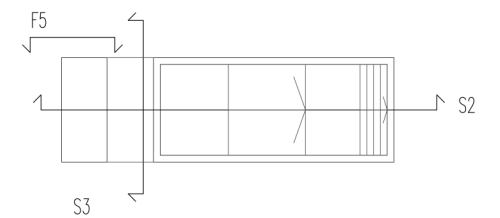

PROPOSTA